



(12) UK Patent (19) GB (11) 2 359 837 (13) B

(54) Title of Invention
Hanging liners by pipe expansion

(51) INT CL⁷: E21B 33/14 17/08 43/10

<p>(21) Application No 01125020</p> <p>(22) Date of filing 04.05.2000</p> <p>(22) Date Lodged 22.05.2001</p> <p>(30) Priority Data</p> <p style="padding-left: 20px;">(31) 09315411</p> <p style="padding-left: 20px;">(32) 20.05.1999</p> <p style="padding-left: 20px;">(33) US</p> <p>(62) Divided from Application No. 0010798.7 under Section 15(4) of the Patents Act 1977</p> <p>(43) Application published 05.09.2001</p> <p>(45) Patent published 10.04.2002</p>	<p>(72) Inventor(s) John L Baugh Rodney J Bennett George E Givens</p> <p>(73) Proprietor(s) Baker Hughes Incorporated</p> <p style="padding-left: 20px;">(Incorporated in USA - Delaware)</p> <p style="padding-left: 20px;">3900 Essex Lane Suite 1200 P.O. Box 4740 Houston Texas 77210-4740 United States of America</p> <p>(74) Agent and/or Address for Service Frank B Dehn & Co 179 Queen Victoria Street London EC4V 4EL United Kingdom</p>
<p>(52) Domestic classification (Edition T) E1F FJT FKG</p> <p>(56) Documents cited GB2346398 A GB2296023 A GB2221482 A</p> <p>(58) Field of search</p> <p style="padding-left: 20px;">As for published application 2359837 A viz: UK CL.(Editi n S) E1F FAC FAW FJT FKG INT CL⁷ E21B 17/08 33/04 33/13 33/14 33/16 43/10 Online: EPODOC, JAPIO, WPI updated as appropriate</p>	

2359837

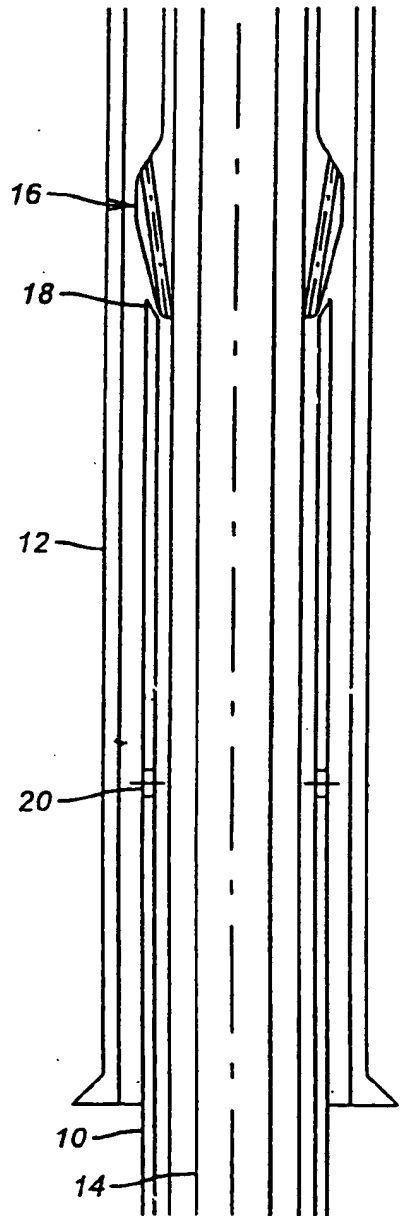

FIG. 1

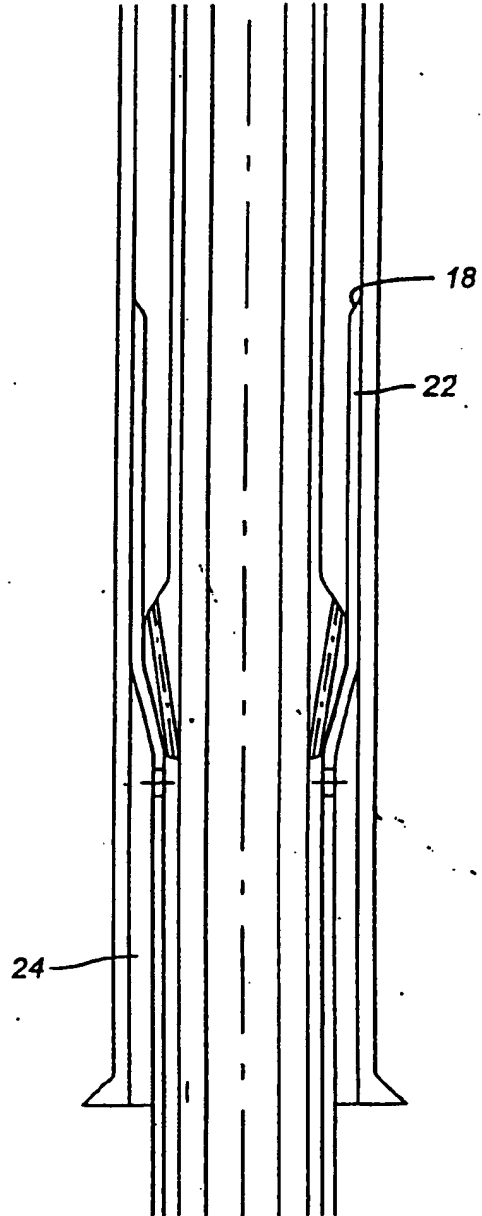

FIG. 2

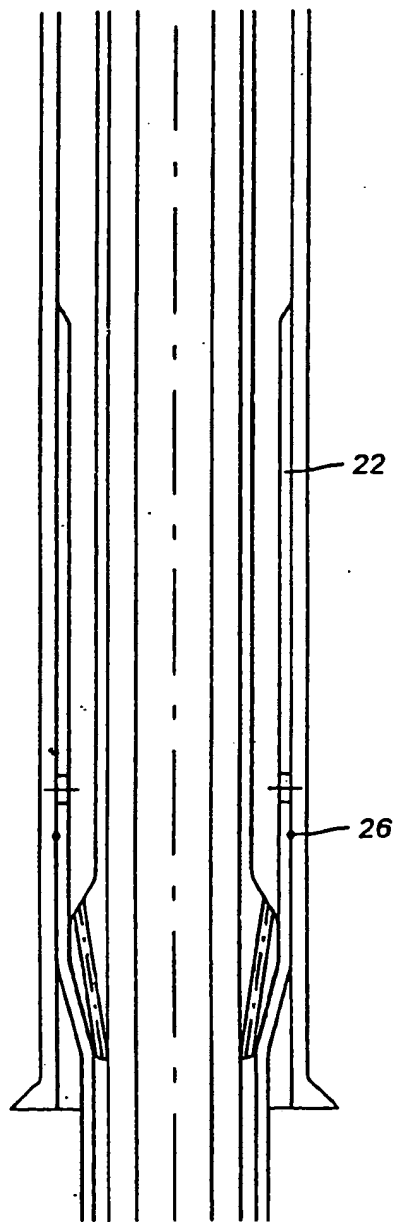

FIG. 3

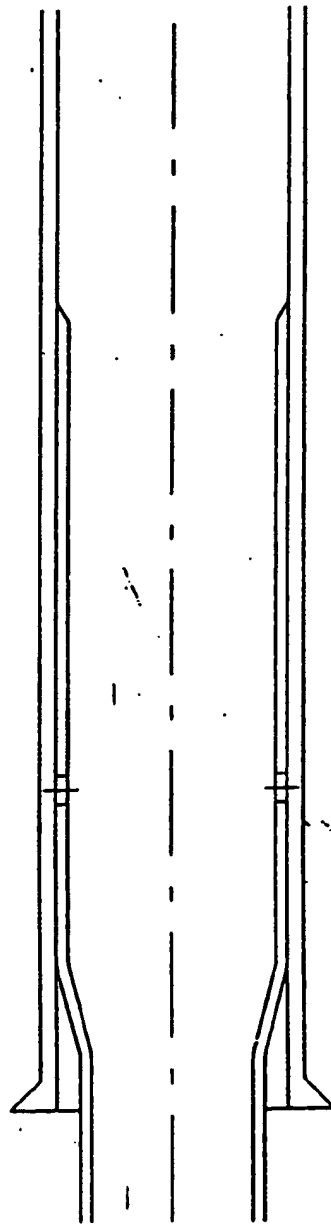

FIG. 4

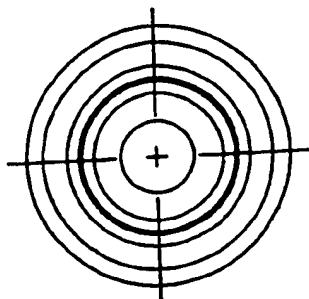

FIG. 6

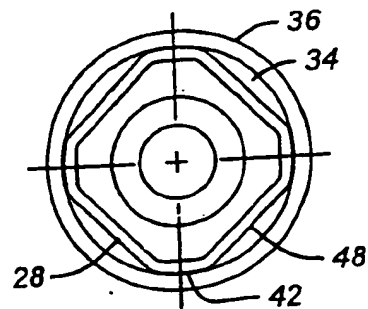

FIG. 8

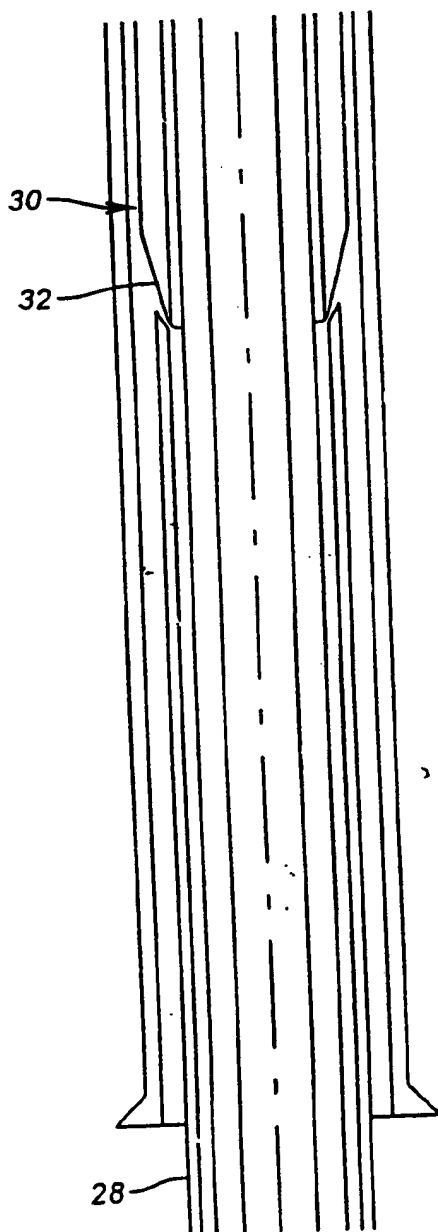

FIG. 5

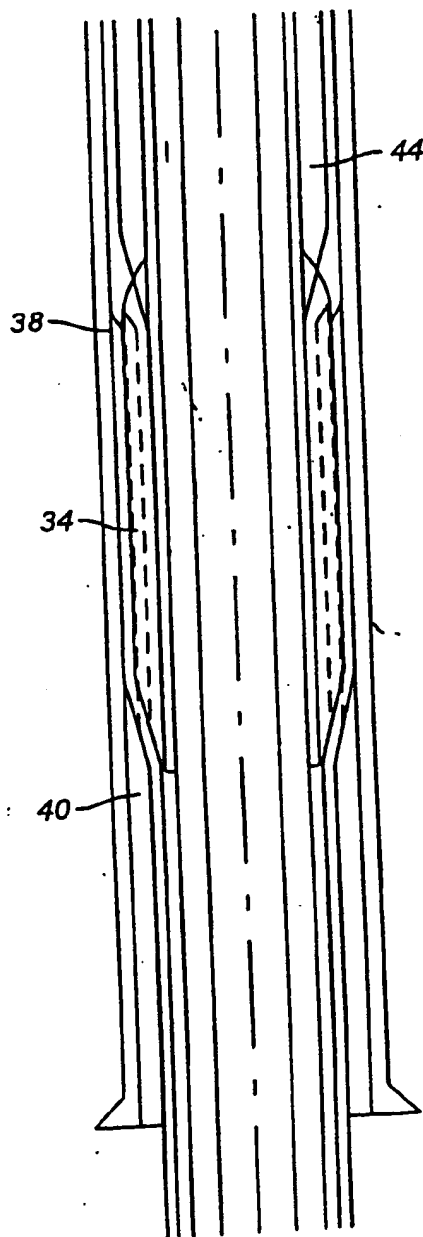

FIG. 7

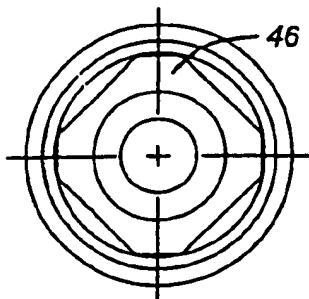

FIG. 10

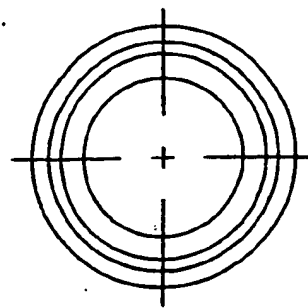

FIG. 11a

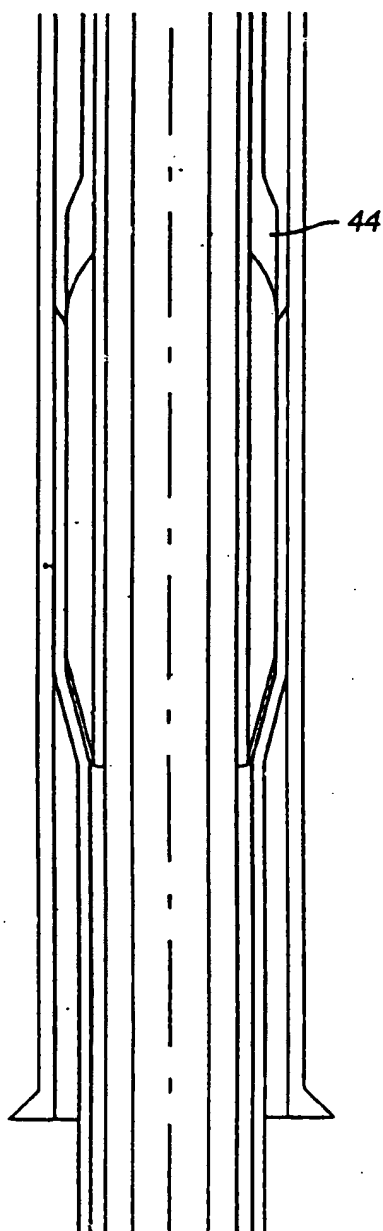

FIG. 9

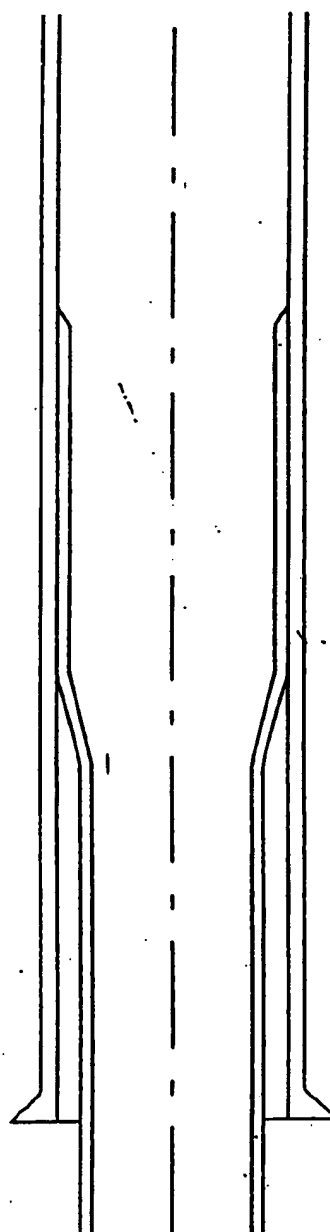

FIG. 10

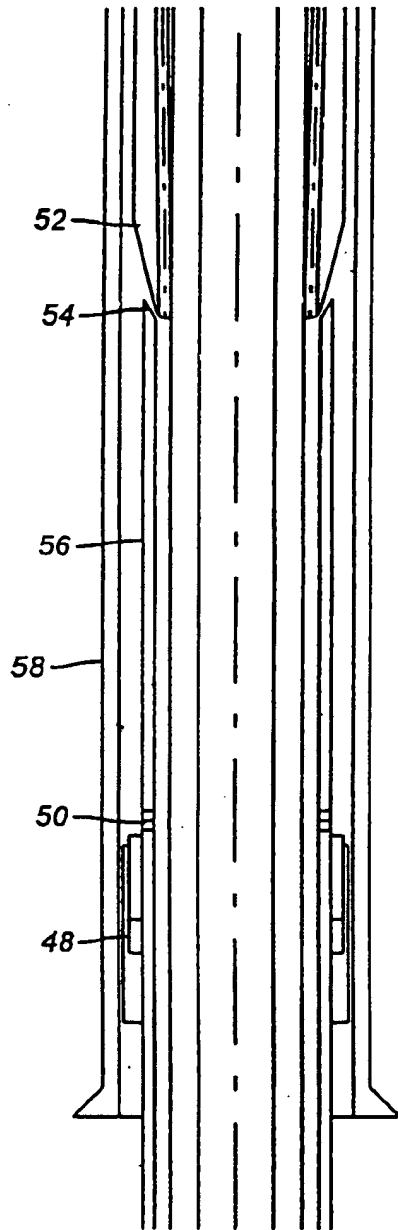

FIG. 12

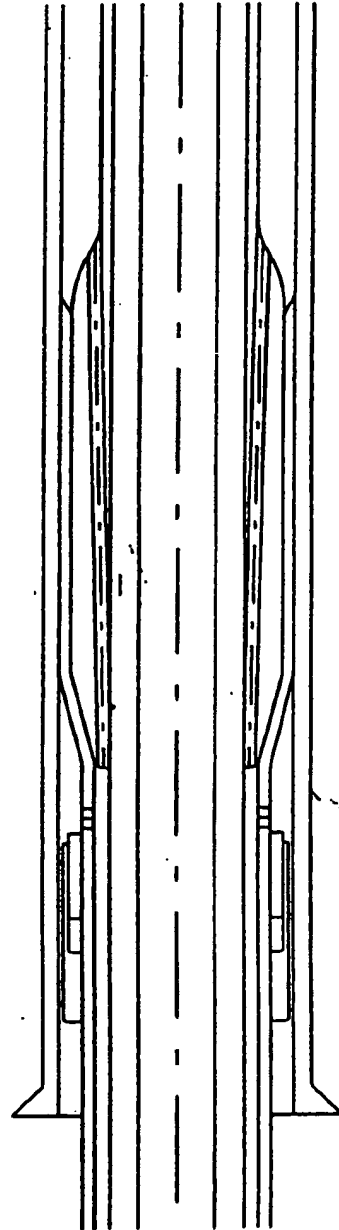

FIG. 13

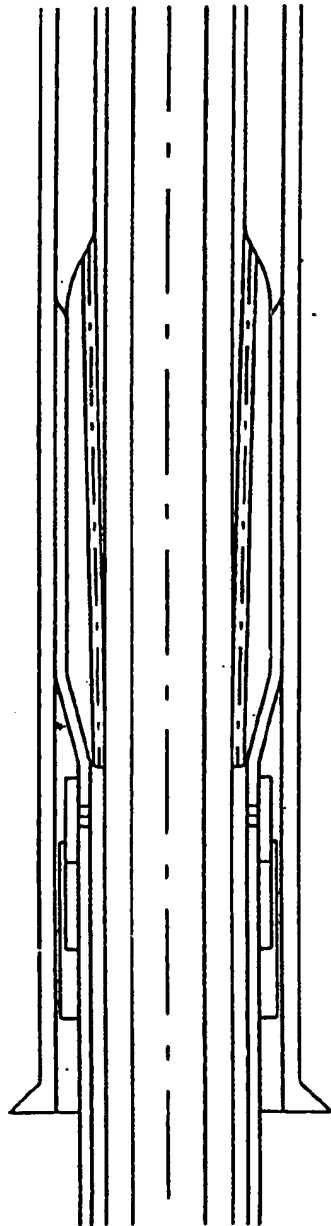

FIG. 14

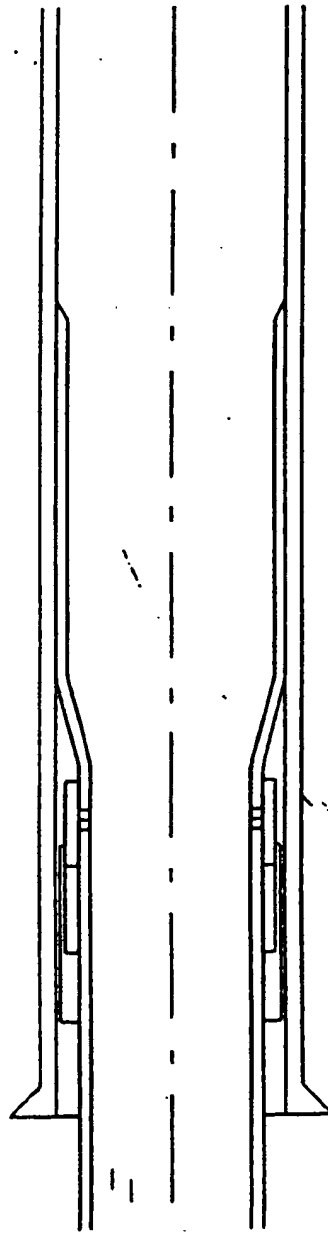

FIG. 15

7/11

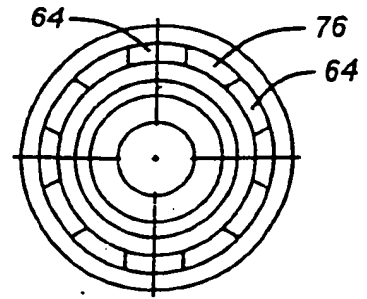

FIG. 17a

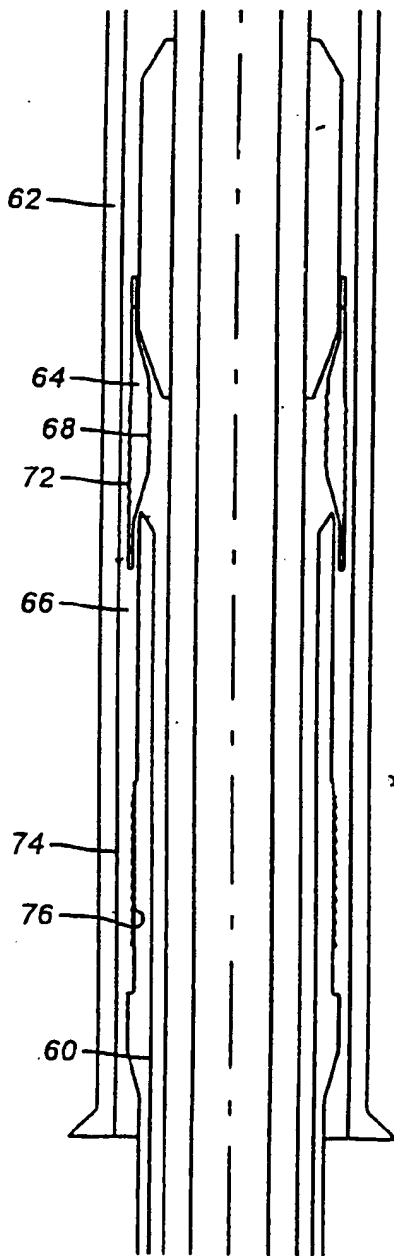

FIG. 16

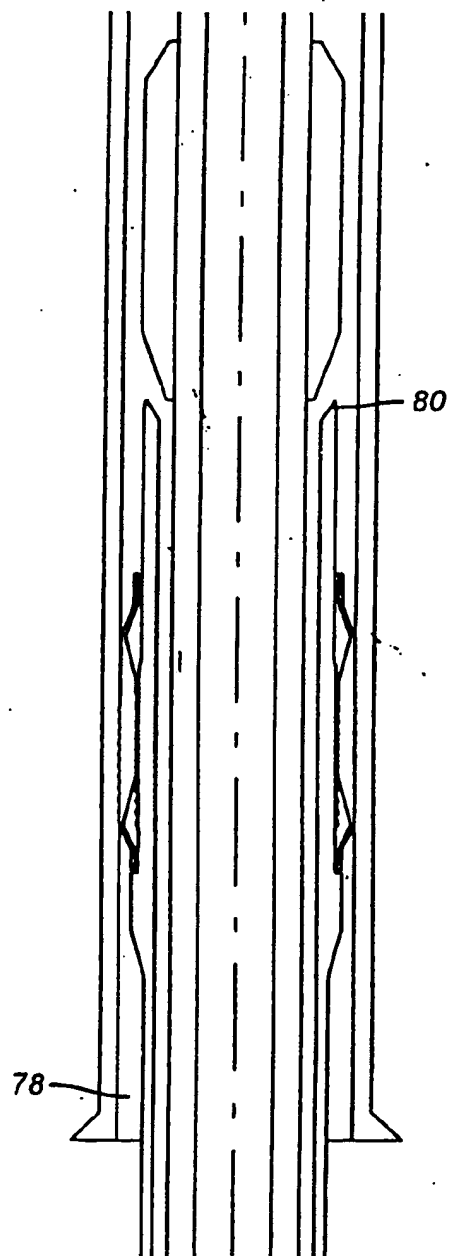

FIG. 17

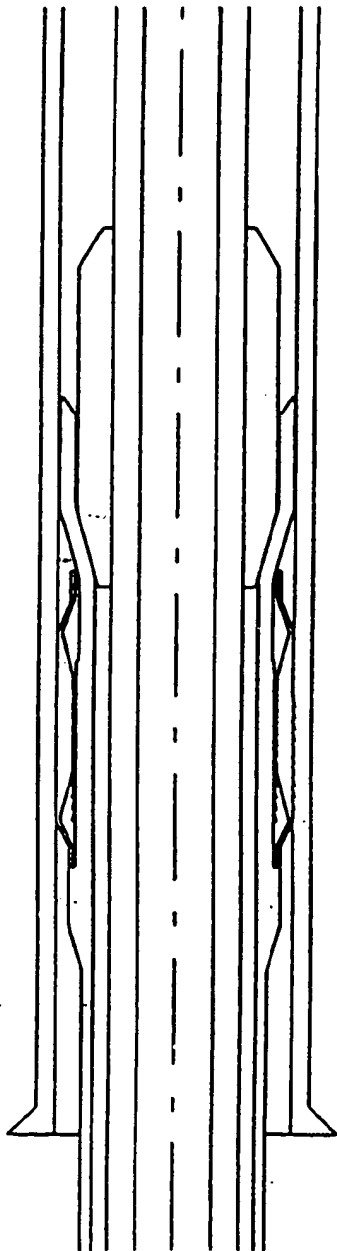

FIG. 18

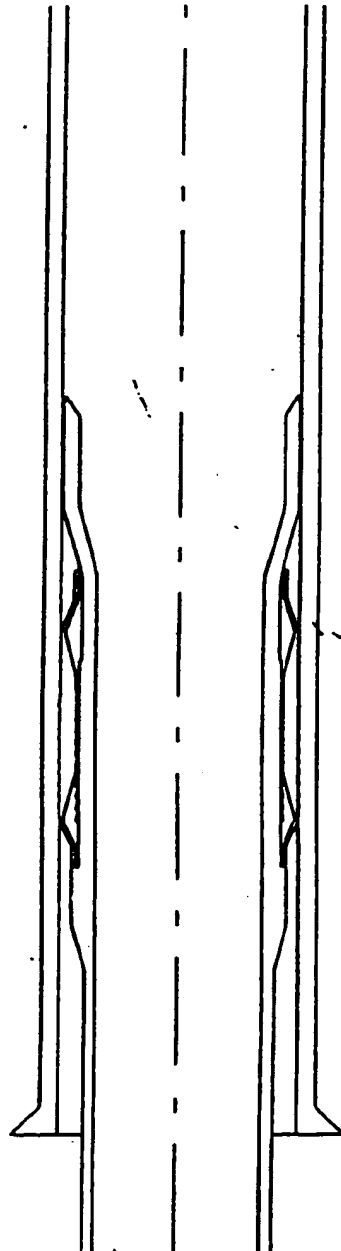

FIG. 19

9/11

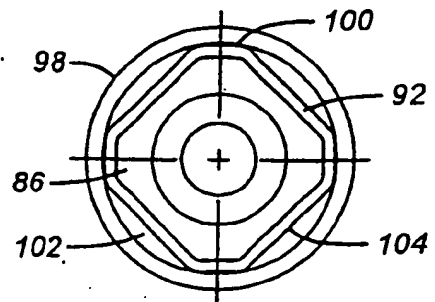

FIG. 22

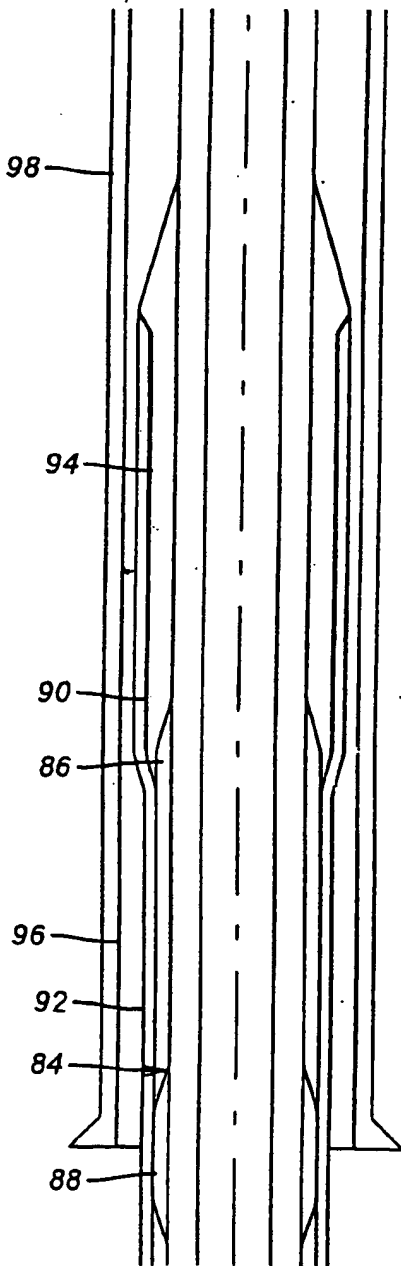

FIG. 20

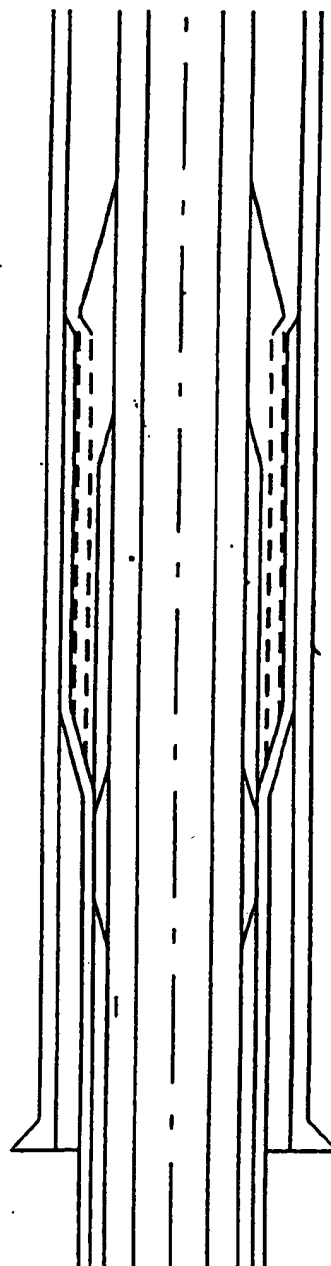

FIG. 21

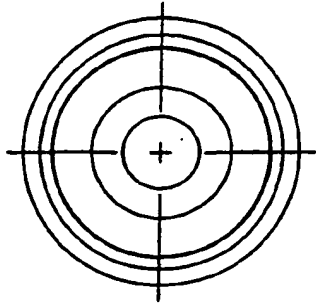

FIG. 24

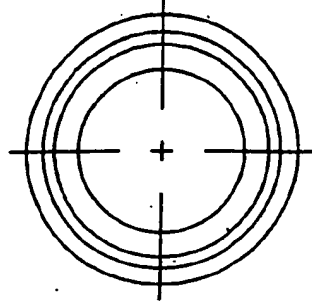

FIG. 26

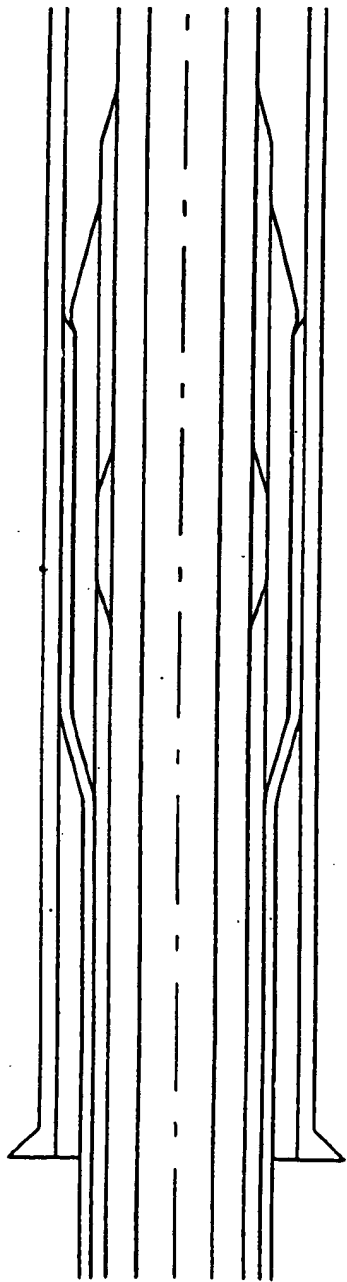

FIG. 23

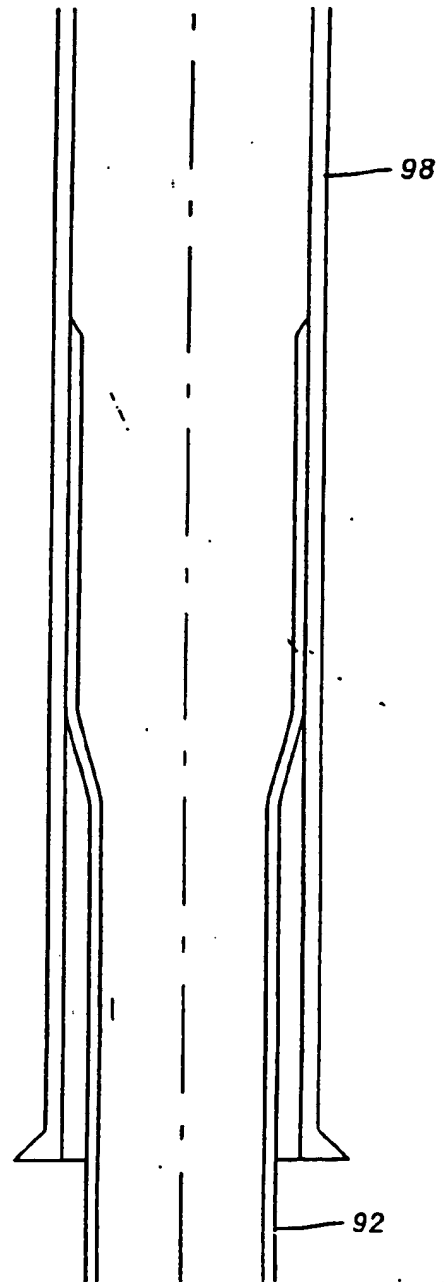

FIG. 25

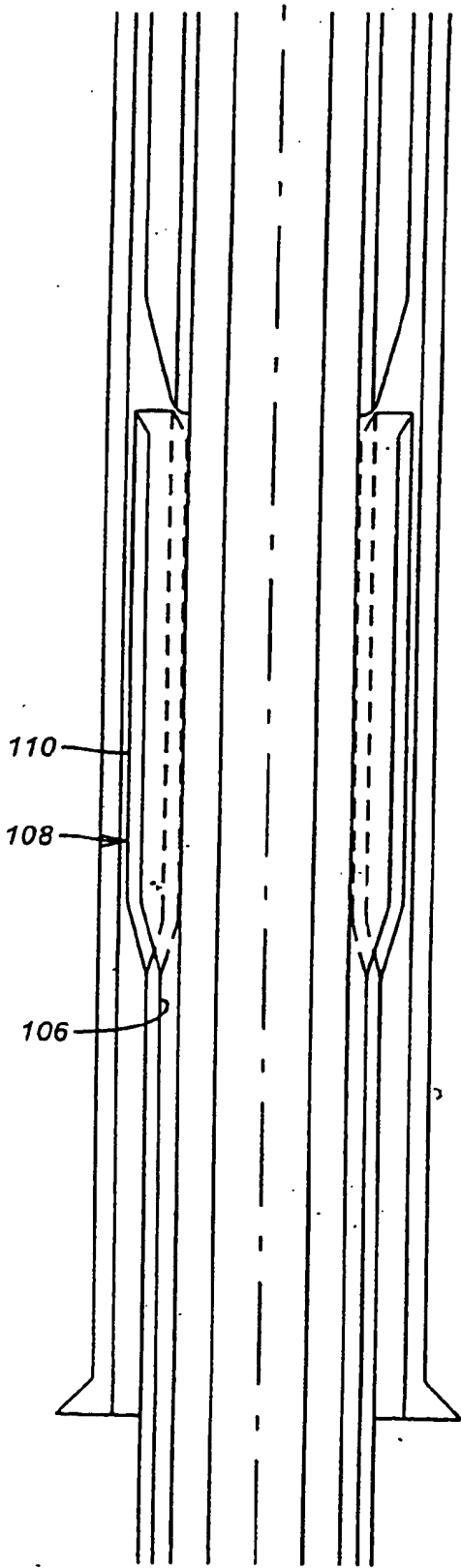

FIG. 27

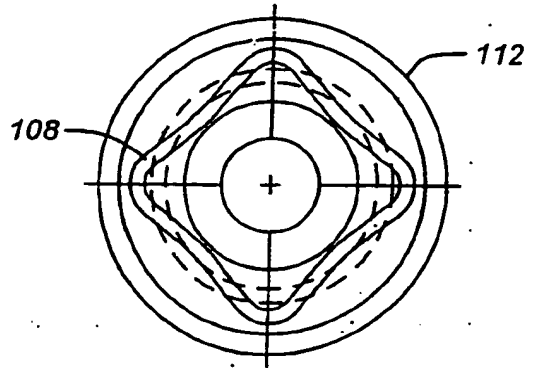

FIG. 28

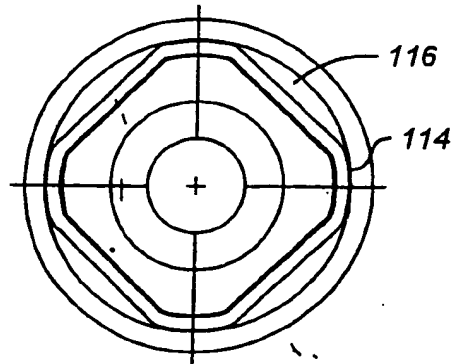

FIG. 29

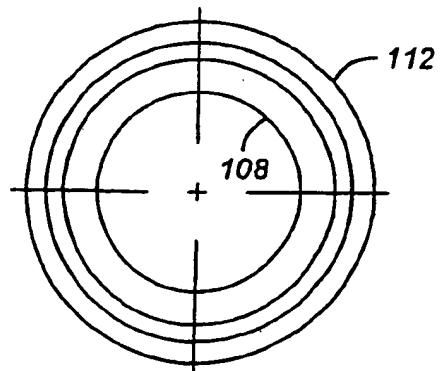

FIG. 30

2359837

HANGING LINERS BY PIPE EXPANSION

5

The field of this invention relates to suspending one tubular in another, especially hanging liners which are to be cemented.

10

In completing wellbores, frequently a liner is inserted into casing and suspended from the casing by a liner hanger. Various designs of liner hangers are known and generally involve a gripping mechanism, such as slips, and a sealing mechanism, such as a packer which can be of a variety of designs.

15

The objective is to suspend the liner during a cementing procedure and set the packer for sealing between the liner and the casing. Liner hanger assemblies are expensive and provide some uncertainty as to their operation down-hole.

20

Some of the objects of the preferred embodiment are to accomplish the functions of the known liner hangers by alternative means, thus eliminating the traditionally known liner hanger altogether while accomplishing its functional purposes at the same time in a single trip into the well. Another objective of the preferred embodiment is to provide alternate techniques which can be used to suspend one tubular in another while facilitating a cementing operation and still providing a technique for sealing the tubulars together. Various fishing tools are known which can be used to support a liner being inserted

25

into a larger tubular. One such device is made by Baker Oil Tools and known as a "Tri-State Type B Casing and Tubing Spear," Product No. 126-09. In addition to known spears which can support a tubing string for lowering into a wellbore, techniques have been developed for expansion of tubulars down-
5 hole. Some of the techniques known in the prior art for expansion of tubulars downhole are illustrated in U.S. Patents 4,976,322; 5,083,608; 5,119,661; 5,348,095; 5,366,012; and 5,667,011.

10 The present invention provides a method as defined in the attached claims.

15 A preferred embodiment of the present invention, together with other arrangements given for illustrative purposes only, will now be described, by way of example only, and with reference to the accompanying drawings in which:

Figures 1-4 are a sectional elevation, showing an arrangement to suspend, cement and seal one tubular to another downhole, using pipe expansion techniques.

20 Figures 5-11a are another arrangement creating longitudinal passages for passage of the cementing material prior to sealing the tubulars together.

Figures 12-15 illustrate yet another arrangement incorporating a sliding sleeve valve for facilitating the cementing step.

25 Figures 16-19 illustrate an embodiment in which a grapple technique is used to suspend the tubular inside a bigger tubular, leaving spaces between the grappling members for passage of cement prior to sealing between the tubulars.

Figures 20-26 illustrate an arrangement involving a sequential flaring of the inner tubular from the bottom up.

Figures 28-30 illustrate an arrangement involving fabrication of the tubular to be inserted to its finished dimension, followed by collapsing it for insertion followed by sequential expansion of it for completion of the operation.

Referring to Figure 1, a tubular 10 is supported in casing 12, using known techniques such as a spear made by Baker Oil Tools, as previously described. That spear or other gripping device is attached to a running string 14. Also located on the running string 14 above the spear is a hydraulic or other type of stroking mechanism which will allow relative movement of a swage assembly 16 which moves in tandem with a portion of the running string 14 when the piston/cylinder combination (not shown) is actuated, bringing the swage 16 down toward the upper end 18 of the tubular 10. As shown in Figure 1 during run-in, the tubular 10 easily fits through the casing 12. The tubular 10 also comprises one or more openings 20 to allow the cement to pass through, as will be explained below. Comparing Figure 2 to Figure 1, the tubular 10 has been expanded radially at its upper end 18 so that a segment 22 is in contact with the casing 12. Segment 22 does not include the openings 20; thus, an annular space 24 exists around the outside of the tubular 10 and inside of the casing 12. While in the position shown in Figure 2, cementing can occur. This procedure involves pumping cement through the tubular 10 down to its lower end where it can come up and around

into the annulus 24 through the openings 20 so that the exterior of the tubular 10 can be fully surrounded with cement up to and including a portion of the casing 12. Before the cement sets, the piston/ cylinder mechanism (not shown) is further actuated so that the swage assembly 16 moves further
• 5 downwardly, as shown in Figure 3. Segment 22 has now grown in Figure 3 so that it encompasses the openings 20. In essence, segment 22 which is now against the casing 12 also includes the openings 20, thereby sealing them off. The seal can be accomplished by the mere physical expansion of segment 22 against the casing 12. Alternatively, a ring seal 26 can be placed
10 below the openings 20 so as to seal the cemented annulus 24 away from the openings 20. Optionally, the ring seal 26 can be a rounded ring that circumscribes each of the openings 20. Additionally, a secondary ring seal similar to 26 can be placed around the segment 22 above the openings 20. As shown in Figure 3, the assembly is now fully set against the casing 12. The
15 openings 20 are sealed and the tubular 10 is fully supported in the casing 12 by the extended segment 22. Referring to Figure 4, the swage assembly 16, as well as the piston/cylinder assembly (not shown) and the spear which was used to support the tubular 10, are removed with the running string 14 so that what remains is the tubular 10 fully cemented and supported in the casing 12.
20 The entire operation has been accomplished in a single trip. Further completion operations in the wellbore are now possible.

Figures 5-12 illustrate an alternative arrangement. Here again, the tubular 28 is supported in a like manner as shown in Figures 1-4, except that
25 the swage assembly 30 has a different configuration. The swage assembly

30 has a lower end 32 which is best seen in cross-section in Figure 8. Lower end 32 has a square or rectangular shape which, when forced against the tubular 28, leaves certain passages 34 between itself and the casing 36. Now referring to Figure 7, it can be seen that when the lower end 32 is brought inside the upper end 38 of the tubular 28, the passages 34 allow communication to annulus 40 so that cementing can take place with the pumped cement going back up the annulus 40 through the passages 34. Referring to Figure 8, it can be seen that the tubular 28 has four locations 42 which are in contact with the casing 36. This longitudinal surface location in contact with the casing 36 provides full support for the tubular 28 during the cementing step. Thus, while the locations 42 press against the inside wall of the casing 36 to support the tubular 28, the cementing procedure can be undertaken in a known manner. At the conclusion of the cementing operation, an upper end 44 of the swage assembly 30 is brought down into the upper end 38 of the tubular 28. The profile of the upper end 44 is seen in Figure 10. It has four locations 46 which protrude outwardly. Each of the locations 46 encounters a mid-point 48 (see Figure 8) of the upper end 38 of the tubular 28. Thus, when the upper end 44 of the swage assembly 30 is brought down into the tubular 28, it reconfigures the shape of the upper end 38 of the tubular 28 from the square pattern shown in Figure 8 to the round pattern shown in Figure 12. Figure 11 shows the running assembly and the swage assembly 30 removed, and the well now ready for the balance of the completion operations. The operation has been accomplished in a single trip into the wellbore. Accordingly, the principal difference in the arrangement shown in Figures 1-4 and that shown in Figures 5-12 is that the first arrangement employed holes

or openings to facilitate the flow of cement, while the second arrangement provides passages for the cement with a two-step expansion of the upper end 38 of the tubular 28. The first step creates the passages 34 using the lower end 32 of the swage assembly 30. It also secures the tubular 28 to the casing 36 at locations 42. After cementing, the upper end 44 of the swage assembly 30 basically finishes the expansion of the upper end 38 of the tubular 28 into a round shape shown in Figure 12. At that point, the tubular 28 is fully supported in the casing 36. Seals, as previously described, can optionally be placed between the tubular 28 and the casing 36 .

10

Another arrangement is illustrated in Figures 12-15. This embodiment has similarities to the embodiment shown in Figures 1-4. One difference is that there is now a sliding sleeve valve 48 which is shown in the open position exposing openings 50. As shown in Figure 12, a swage assembly 52 fully expands the upper end 54 of the tubular 56 against the casing 58, just short of openings 50. This is seen in Figure 13. At this point, the tubular 56 is fully supported in the casing 58. Since the openings 50 are exposed with the sliding sleeve valve 48, cementing can now take place. At the conclusion of the cementing step, the sliding sleeve valve 48 is actuated in a known manner to close it off, as shown in Figure 14. Optionally, seals can be used between tubular 56 and casing 58. The running assembly, including the swage assembly 52, is then removed from the tubular 56 and the casing 58, as shown in Figure 15. Again, the procedure is accomplished in a single trip. Completion operations can now continue in the wellbore.

15

20

Figures 16-19 illustrate an embodiment of the invention. The initial support of the tubular 60 to the casing 62 is accomplished by forcing a grapple member 64 down into an annular space 66 such that its teeth 68 ratchet down over teeth 70, thus forcing teeth 72, which are on the opposite side of the grappling member 64 from teeth 68, to fully engage the inner wall 74 of the casing 62. This position is shown in Figure 17, where the teeth 68 and 70 have engaged, thus supporting the tubular 60 in the casing 62 by forcing the teeth 72 to dig into the inner wall 74 of the casing 62. The grapple members 64 are elongated structures that are placed in a spaced relationship as shown in Figure 17A. The spaces 76 are shown between the grapple members 64. Thus, passages 76 provide the avenue for cement to come up around annulus 78 toward the upper end 80 of the tubular 60. At the conclusion of the cementing, the swage assembly 82 is brought down into the upper end 80 of the tubular 60 to flare it outwardly into sealing contact with the inside wall 74 of the casing 62, as shown in Figure 18. Again, a seal can be used optionally between the upper end 80 and the casing 62 to seal in addition to the forcing of the upper end 80 against the inner wall 74, shown in Figure 18. The running assembly as well as the swage assembly 82 is shown fully removed in Figure 19 and further downhole completion operations can be concluded. All the steps are accomplished in a single trip.

Figures 20-25 illustrate yet another arrangement. In this situation, the swage assembly 84 has an upper end 86 and a lower end 88. In the run-in position shown in Figure 20, the upper end 86 is located below a flared out portion 90 of the tubular 92. Located above the upper end 86 is a sleeve 94 which is preferably made of a softer material than the tubular

92, such as aluminum, for example. The outside diameter of the flared out segment 90 is still less than the inside diameter 96 of the casing 98. Ultimately, the flared out portion 90 is to be expanded, as shown in Figure 21, into contact with the inside wall of the casing 98. Since that distance representing that expansion cannot physically be accomplished by the upper end 96 because of its placement below the flared out portion 90, the sleeve 94 is employed to transfer the radially expanding force to make initial contact with the inner wall of casing 98. The upper end 86 of the swage assembly 84 has the shape shown in Figure 22 so that several sections 100 of the tubular 92 will be forced against the casing 98, leaving longitudinal gaps 102 for passage of cement. In the position shown in Figures 21 and 22, the passages 102 are in position and the sections 100 which have been forced against the casing 98 fully support the tubular 92. At the conclusion of the cementing operation, the lower segment 88 comes into contact with sleeve 94. The shape of lower end 88 is such so as to fully round out the flared out portion 90 by engaging mid-points 104 of the flared out portion 90 (see Figure 22) such that the passages 102 are eliminated as the sleeve 94 and the flared out portion 90 are in tandem pressed in a manner to fully round them, leaving the flared out portion 90 rigidly against the inside wall of the casing 98. This is shown in Figure 23. Figure 25 illustrates the removal of the swage assembly 84 and the tubular 92 fully engaged and cemented to the casing 98 so that further completion operations can take place. Figures 24 and 26 fully illustrate the flared out portion 90 pushed hard against the casing 98. Again, in this arrangement as in all the others, auxiliary sealing devices can be used be-

tween the tubular 92 and the casing 98 and the process is done in a single trip.

Referring now to Figures 27-30, yet another arrangement is illustrated. Again, the similarities in the running in procedure will not be repeated because they are identical to the previously described arrangements. In this situation, the tubular 106 is initially formed with a flared out section 108. The diameter of the outer surface 110 is initially produced to be the finished diameter desired for support of the tubular 106 in a casing 112 (see Figure 28) in which it is to be inserted. However, prior to the insertion into the casing 112 and as shown in Figure 28, the flared out section 108 is corrugated to reduce its outside diameter so that it can run through the inside diameter of the casing 112. The manner of corrugation or other diameter-reducing technique can be any one of a variety of different ways so long as the overall profile is such that it will pass through the casing 112. Using a swage assembly of the type previously described, which is in a shape conforming to the corrugations illustrated in Figure 28 but tapered to a somewhat larger dimension, the shape shown in Figure 29 is attained. The shape in Figure 29 is similar to that in Figure 28 except that the overall dimensions have been increased to the point that there are locations 114 in contact with the casing 112. These longitudinal contacts in several locations, as shown in Figure 29, fully support the tubular 106 in the casing 112 and leave passages 116 for the flow of cement. The swage assembly can be akin to that used in Figures 5-11 in the sense that the corrugated shape now in contact with the casing 112 shown in Figures 29 at locations 114 can be made into a round shape at the conclusion of the cementing operation. Thus, a second portion of the swage assembly as

previously described is used to contact the flared out portion 108 in the areas where it is still bent, defining passages 116, to push those radially outwardly until a perfect full 360° contact is achieved between the flared out section 108 and the casing 112, as shown in Figure 30. This is all done in a single trip.

5 Those skilled in the art can readily appreciate that various arrangements have been disclosed which allow a tubular, such as 10, to be suspended in a running assembly. The running assembly is of a known design and has the capability not only of supporting the tubular for run-in but also to actuate a swage assembly of the type shown, for example, in Figure 1 as item 16. What
10 is common to all these techniques is that the tubular is first made to be supported by the casing due to a physical expansion technique. The cementing takes place next and the cementing passages are then closed off. Since it is important to allow passages for the flow of cement, the apparatus of the present invention provides a technique which
15 allows this to happen with the tubular supported while subsequently closing them off. The technique can work with a swage assembly which is moved downwardly into the top end of the tubular or in another arrangement, such as shown in Figures 20-26, the swage assembly is moved upwardly, out of the top end of the tubular. The creation of passages for the cement, such as 34
20 in Figure 8, 76 in Figure 17A, or 102 in Figure 22, can be accomplished in a variety of ways. The nature of the initial contact used to support the tubular in the casing can vary. Thus, although four locations are illustrated for the initial support contact in Figure 8, a different number of such locations can be used. Different materials can be used to encase the liner up

and into the casing from which it is suspended, including cement, blast furnace slag, or other materials. Known techniques are used for operating the sliding sleeve valve shown in Figure 12-15, which selectively exposes the openings 50. Other types of known valve assemblies are also contemplated. Despite the variations, the technique winds up being a one-trip operation.

5

Those skilled in the art will now appreciate that what has been disclosed is a method which can completely replace known liner hangers and allows for sealing and suspension of tubulars in larger tubulars, with the flexibility of cementing or otherwise encasing the inserted tubular into the larger tubular.

10

The foregoing disclosure and description of the invention are illustrative and explanatory thereof, and various changes in the size, shape and materials, as well as in the details of the illustrated construction, may be made.

73075001.355

1. The method of completing a well, comprising:
5 running in a tubular string into a cased borehole;
 inserting at least one gripping member between said
tubular string and cased borehole to support said
tubular string;
 leaving a gap adjacent said gripping member;
 flowing a sealing material through said gap;
10 sealing said gap.

2. The method of claim 1, further comprising:
 expanding said tubular string uphole of said
gripping member as said sealing said gap.
15

3. The method of claim 2, further comprising:
 providing a plurality of gripping members to
support said tubular string;
 wedging said gripping members in a spaced relation
20 to each other to create longitudinal gaps between said
tubular string and said cased borehole for flow of said
sealing material.

4. The method of claim 3, further comprising:
25 wedging said gripping members below a top end of
said tubular string;
 expanding said tubular string between said top end
and said gripping members into sealing contact with said
cased borehole.
30

5. The method of claim 4, further comprising:
 accomplishing said running in, inserting the
gripping member, leaving a gap, flowing the sealing
material, and sealing said gap in a single trip in the
35 well.